

PRODUCT INFORMATION PACKET



Model No: OKR1096V1
Catalog No: OKR1096V1
0.5 HP Condenser Fans HVAC/R Motor, 3 phase, 1200 RPM, 208-230/460 V, 56 Frame, TEAO
Condenser Fans Motors



Regal and Century are trademarks of Regal Beloit Corporation or one of its affiliated companies.
©2019 Regal Beloit Corporation, All Rights Reserved. MC017097E





Nameplate Specifications

Output HP	0.5 Hp	Output KW	0.37 kW
Frequency	60 Hz	Voltage	208-230/460 V
Current	2.1-2.0/1.0 A	Speed	1140 rpm
Service Factor	1	Phase	3
Duty	Continuous	Insulation Class	B
Frame	56	Enclosure	Totally Enclosed Air Over
Thermal Protection	Thermally Protected	Ambient Temperature	40 °C
UL	Recognized	CSA	Y
CE	N		

Technical Specifications

Electrical Type	Three Phase	Starting Method	Across The Line
Poles	6	Rotation	Reversible
Mounting	Round	Drive End Bearing	Ball
Opp Drive End Bearing	Ball	Frame Material	Rolled Steel
Shaft Type	Flat	Overall Length	11.96 in
Frame Length	7.25 in	Shaft Diameter	0.625 in
Shaft Extension	1.91 in		

This is an uncontrolled document once printed or downloaded and is subject to change without notice. Date Created:30/10/2019

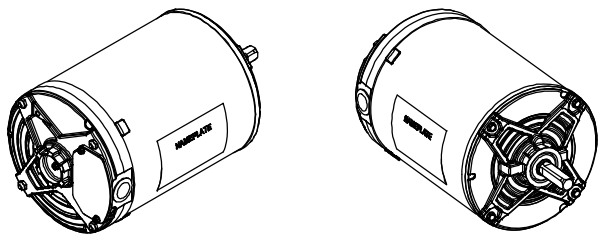
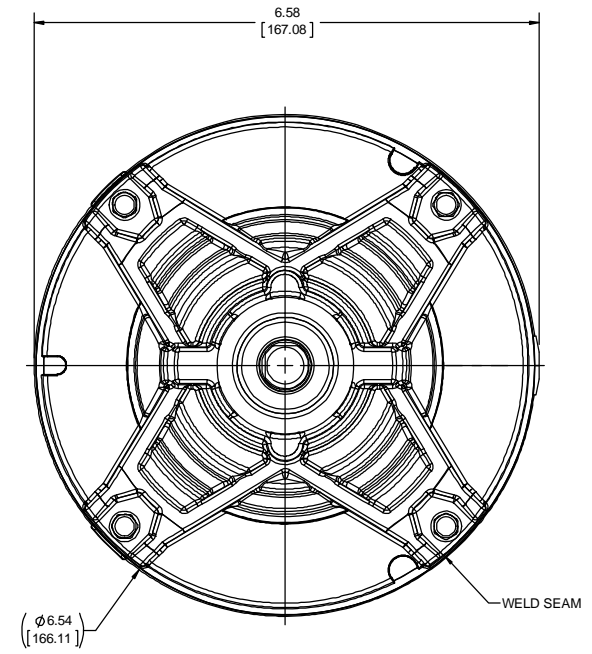
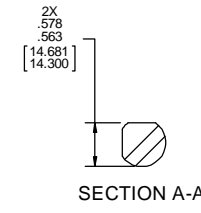
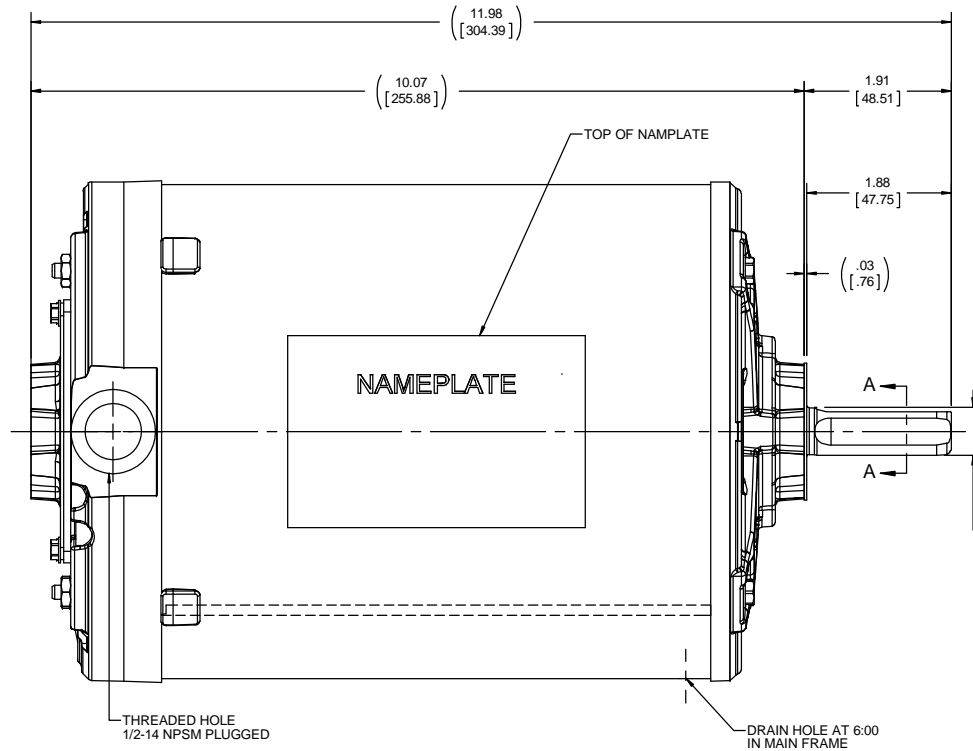

DRAWING REVISION A		REVISION BY	DATE	TOLERANCES UNLESS OTHERWISE SPECIFIED:		DRAWN BY F. RAMIREZ	
ECO-0125539	APPROVED BY	DATE	DEC.	INCH	mm	ANGLE	DATE 07-01-2017
ECO DESCRIPTION NEW			.X	±0.1	[±2.5]	±7 30°	APPROVED BY
COPYRIGHT REGAL BELOIT AMERICA, INC. ALL RIGHTS RESERVED. PROPRIETARY AND CONFIDENTIAL INFORMATION. THIS DOCUMENT IS THE PROPERTY OF REGAL BELOIT AMERICA, INC. FORMERLY AND CONTAINING OWNERS PROPRIETARY INFORMATION. ANY PERSON, CORPORATION OR OTHER FIRM RECEIVING IT IS DEEMED BY RECEIVING IT, TO AGREE THAT IT, AND/OR ANY PART OF IT, SHALL NOT BE DISCLOSED TO ANY PERSON, CORPORATION OR OTHER ENTITY, DUPLICATED, AND/OR USED, EXCEPT AS EXPRESSLY APPROVED IN WRITING IN ADVANCE BY OWNER. THIS DOCUMENT SHALL BE RETURNED TO OWNER UPON REQUEST. IT MAY BE SUBJECT TO CERTAIN RESTRICTIONS UNDER APPLICABLE EXPORT CONTROL LAWS AND REGULATIONS.			.XX	±0.02	[±0.51]		DATE
			.XXX	±0.005	[±0.127]		REFERENCE OKR1096
			.XXXX	±0.0005	[±0.0127]		MATERIAL
			REMOVE BURRS & BREAK SHARP EDGES: .003/.015 [0.076/.381]				PROCESS/FINISH
			CORNER FILLETS: .02 [.51]				SIZE
			MACHINED SURFACES: 200 / 5.1 INCH / mm SHOWN IN (BRACKETS)				DRAWING NUMBER
							THIRD ANGLE PROJECTION
							1
							DESCRIPTION OUTLINE
							REGAL™ Regal Beloit America, Inc.
							1 OF 1
							OL56100259-001