

PRODUCT INFORMATION PACKET



Model No: 250
Catalog No: 250
25 WATT Refrigeration Motor, 1500 RPM, 115 Volts, Unit Bearing,TEAO
Unit Bearing Motors



Regal and Century are trademarks of Regal Beloit Corporation or one of its affiliated companies.
©2020 Regal Beloit Corporation, All Rights Reserved. MC017097E





Nameplate Specifications

Output Watts	25 W	Frequency	60 Hz
Voltage	115 V	Current	1.1 A
Speed	1500 rpm	Service Factor	1
Phase	1	Duty	Continuous
Insulation Class	A	Frame	UNIT BEARING
Enclosure	Totally Enclosed Air Over	Thermal Protection	Thermally Protected
Ambient Temperature	40 °C	UL	Recognized
CSA	Y	CE	N

Technical Specifications

Electrical Type	Shaded Pole	Starting Method	Across The Line
Poles	4	Rotation	Clockwise Lead End
Mounting	2 BOSS/OSE 3 HOLES	Drive End Bearing	Unit
Opp Drive End Bearing	Unit	Frame Material	Cast Iron
Shaft Type	Threaded	Frame Length	3.84 in
Shaft Diameter	1/4x20 in	Shaft Extension	0.52 in
Outline Drawing	250-S01		

This is an uncontrolled document once printed or downloaded and is subject to change without notice. Date Created:26/08/2020

NO. A-23089

NO.	REVISIONS	DATE AND SIGNATURE
1	ADDED MODEL NUMBERS	11-9-94
2	LEAD WAS (2) #10 EYELETS	7-*6-98
3	CUST NAME CHANGED WAS MAGNETEK	6-07-02

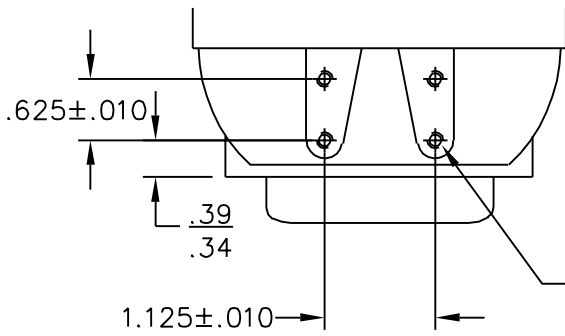

OUTLINE DIMENSIONS ON WHICH NO LIMIT IS SPECIFIED ARE NOMINAL AND NOT GUARANTEED AS TO TOLERANCE. ADDITIONAL INFORMATION ON TOLERANCE WILL BE FURNISHED ON SPECIFIC REQUEST.

"M" MOUNTING
#8-36 N.F. 4 HOLES TAPPED THRU
BOTH SIDES

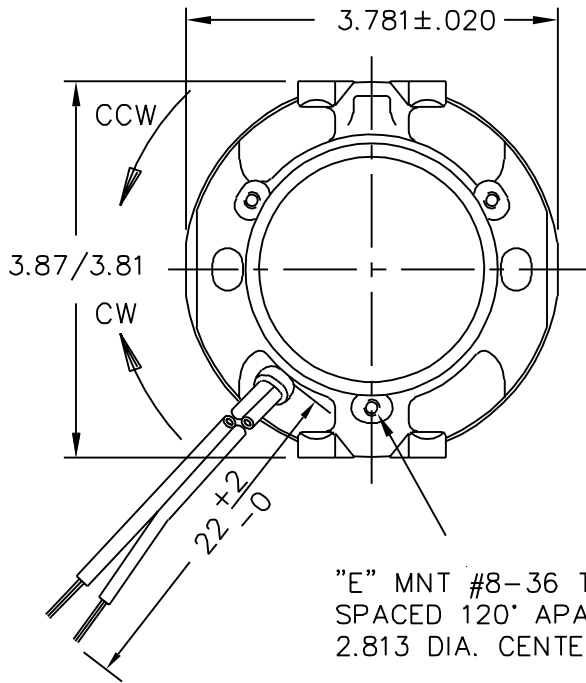

"E" MNT #8-36 TAPPED HOLES
SPACED 120° APART ON A
2.813 DIA. CENTER LINE.

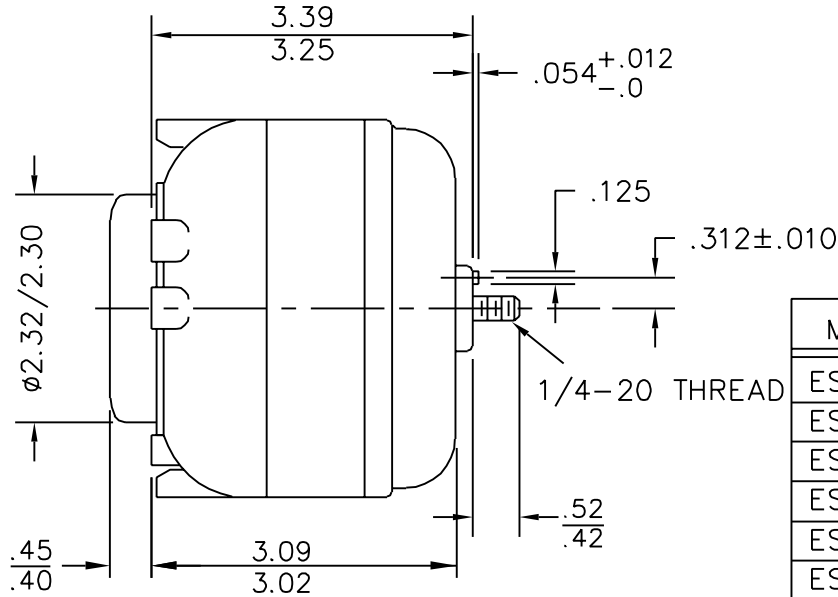

A.O. SMITH

MODEL	CUST NO.
ESP-L16EM1	= 246
ESP-L16EM2	= 248
ESP-L16EMR1	= 247
ESP-L16EMR2	= 249
ESP-L25EM1	= 250
ESP-L25EM2	= 252
ESP-L25EMR1	= 251
ESP-L25EMR2	= 253
ESP-L35EM1	= 254
ESP-L35EM2	= 256
ESP-L35EMR1	= 255
ESP-L35EMR2	= 257

R = CCW ROTATION

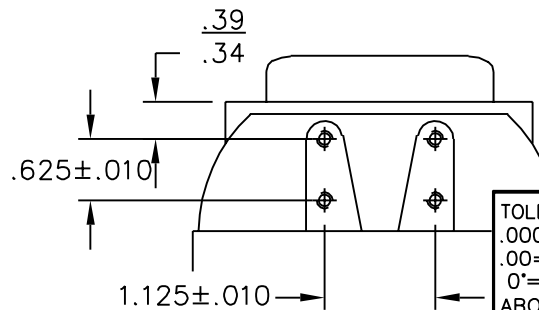

TOLERANCE
.0000=±.0002 .000=±.005
.00=±.010 FRACTION=±1/64
0°=±30' 0'0°=±5' 0'0'0°=REF. ONLY
ABOVE TOLERANCES APPLY UNLESS
OTHERWISE SPECIFIED TOLERANCES
ARE NOT ACCUMULATIVE.

ELECTRIC MOTORS AND SPECIALTIES INC.			
230V 60/50HZ CW GARRETT, INDIANA 46738			
FIRST MADE FOR ESP-L16EM2		A.O. SMITH	
MATERIAL		CUST NO. 248	
DRAWN BY JIM NICTER	DATE 4-11-94	SCALE 1/2 SIZE	APPROVED BY DATE
TITLE MOTOR OUTLINE			NO. A-23089